

TS400 Rev. B 07/16



MODEL : SLK-TS400

Receipt Printer User's Manual

All specifications are subject to change without notice



Disposal of Old Electrical&Electronic Equipment(Applicable in the European Union and other European countries with separate collection systems)

This symbol on the product or on its packaging indicates that this product shall not be treated as household waste. Instead it shall be handed over to the applicable collection point for the recycling of electrical and electronics equipment. For more detailed information about recycling of this product, please contact your local city office, your household waste disposal service or the shop where you purchased the product.

Table of Contents

1. Parts Identifications	3
2. Setting up the printer	4
2.1 Unpacking	4
2.2 Connecting the cables	5
2.3 Loading the roll paper	8
3. Control panel and other functions	11
3.1 Control panel	11
3.2 Error Indicating	11
4. Self Test	12
5. ASCII Print	13
6. Select Baudrate Mode	13
7. Hexadecimal Dump	14
8. Select Error Beep Mode	14
9. Peripherals Connection	15
10. Printer cleaning	16
11. Specifications	17
11.1. General Specifications	17
11.2. Auto Cutter Specifications	18
11.3. Interface	18
11.4. Electrical Characteristics	18
11.5. Environmental Requirements	19
11.6. Reliability	19
11.7. Certification	19
12. Command List	20

1. Parts Identifications

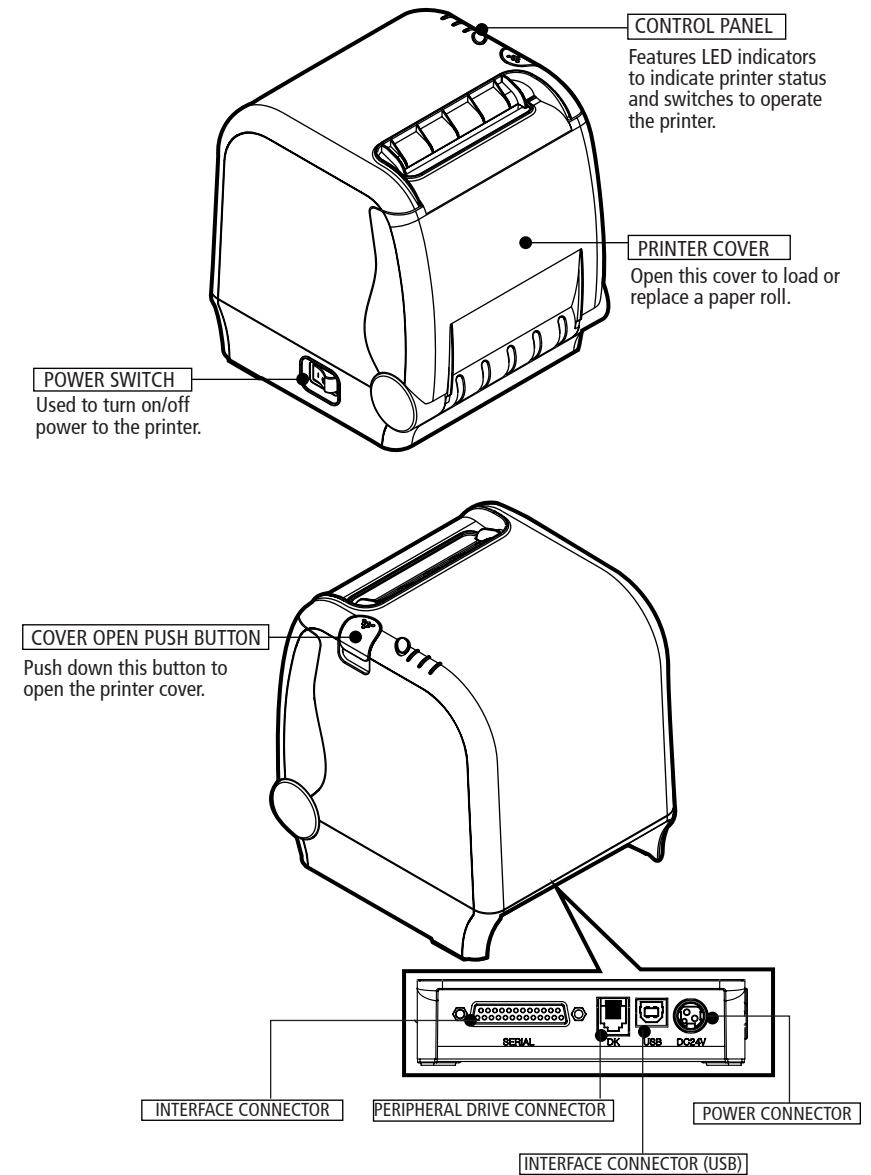

2. Setting Up the Printer

2-1. Unpacking

Your printer box should include these items. If any items are damaged or missing, please contact your dealer for assistance.

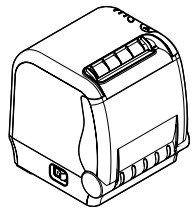

The Printer



CD

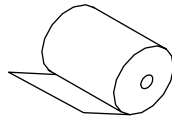

Roll Paper

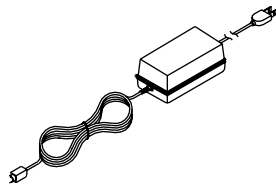

Adaptor(option)

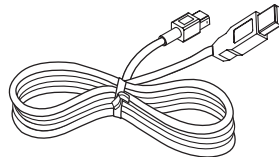

USB Cable(option)

2-2. Connecting the Cables

All cables connect to the connector panel on the back of the printer which is shown below:

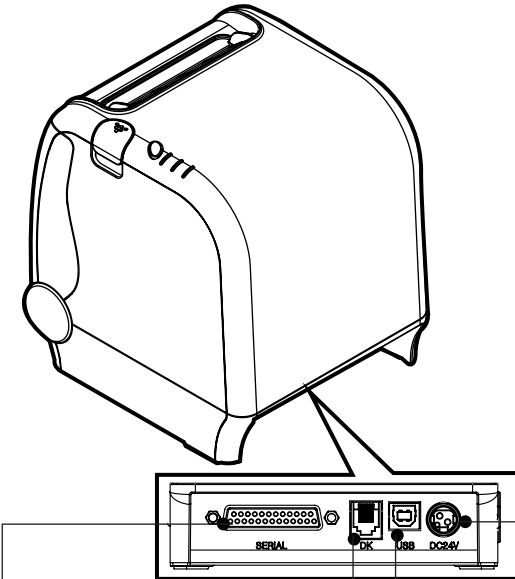

INTERFACE CONNECTOR

For connection to a host computer.

PERIPHERAL DRIVE CONNECTOR

Connects to peripheral units such as cash drawer, etc.
Do not connect this to a telephone.

INTERFACE CONNECTOR (USB)

For connection to a host computer.

POWER CONNECTOR

For connection of the AC adapter.
Never unplug the AC adapter while the printer is on.

Before connecting any of the cables, make sure that both the printer and the computer are turned off.

2-2-1. Interface Connector

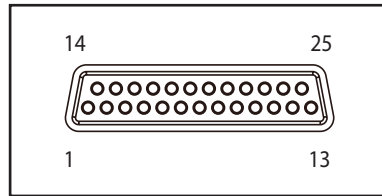

<D-SUB 25 Female Serial>

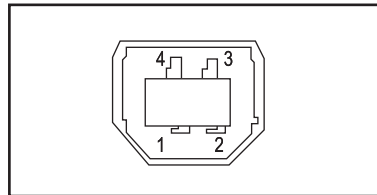

<USB "B" Type>

25Pin Serial Interface

Pin	Signal	I/O	Description
2	TxD	Output	Printer transmit data line RS-232C level
3	RxD	Input	Printer receive data line RS-232C level
4, 20	DTR	Output	Printer handshake to host line RS-232C level
6	DSR	Input	Data Send Ready
1,7	GND	-	System Ground

USB Interface

Pin	Signal	I/O	Description
1	+5V	-	+5V
2	DATA-	-	Printer transmit data line
3	DATA+	-	Printer transmit data line
4	GND	-	System Ground

2-2-2. Cash Drawer Connector

The printer can operate two cash drawers with a 6 pin RJ-11 modular connector.

The driver is capable of supplying a maximum current of 1.0A for 510ms or less when not printing.

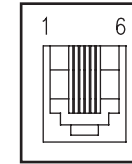

PIN	SIGNAL	DESCRIPTION
1	Signal GND	-
2	Drawer kick-out drive signal 1	Output
3	Drawer open/close signal	Input
4	+24V	-
5	Drawer kick-out drive signal 2	Output
6	Signal GND	-

♣ NOTE:

Cash drawer 1 and 2 are connected each other inside the printer.

As it is not able to distinguish between Cash drawer 1 and 2,

we recommend you to use only one cash drawer.

2-3. Loading the Roll Paper

Notes: Be sure to use paper rolls that meet the specifications. Do not use paper rolls that have the paper glued to the core because the printer cannot detect the paper end correctly.

♣ Turn off power switch.

1. Make sure that the printer is not receiving data; Otherwise, data may be lost.
2. Open the printer cover by pushing down the cover open push button.

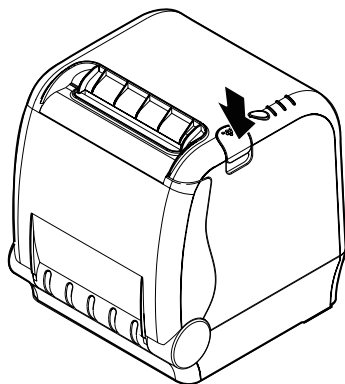

3. Remove the used paper roll core if there is one inside.
4. Insert new paper roll as shown.

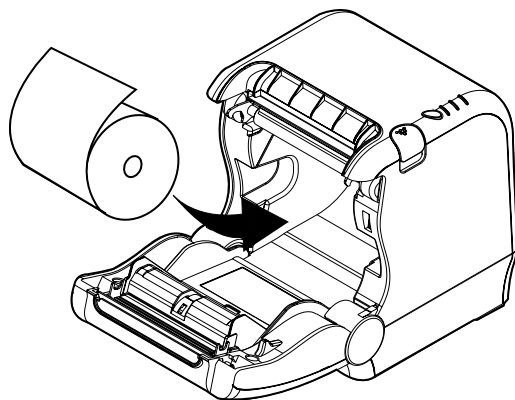

5. Note the correct direction that the paper comes off the roll:

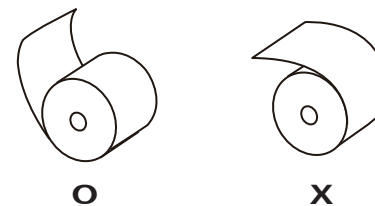

6. Pull out a small amount of paper roll as shown. Then, close the cover.

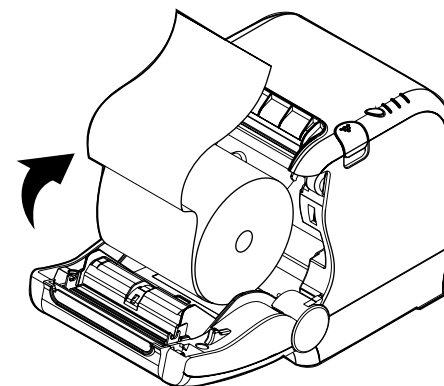

7. Tear off the paper as shown.

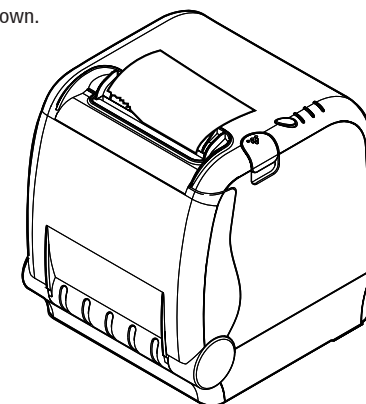

♣CAUTION:

When the cutter is jammed, please follow the steps below.

1. Turn off the power.
2. Press the cover open button and open the cover.
: Be carefull of cutter blade because the cutter blade might be come out.

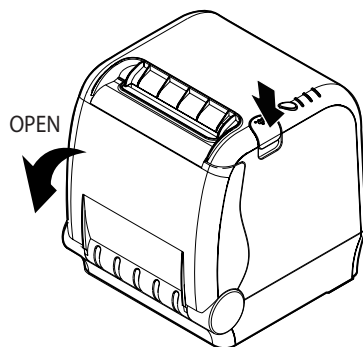

3. Turn on the power, the cutter will automatically reset.

4. Close the cover.

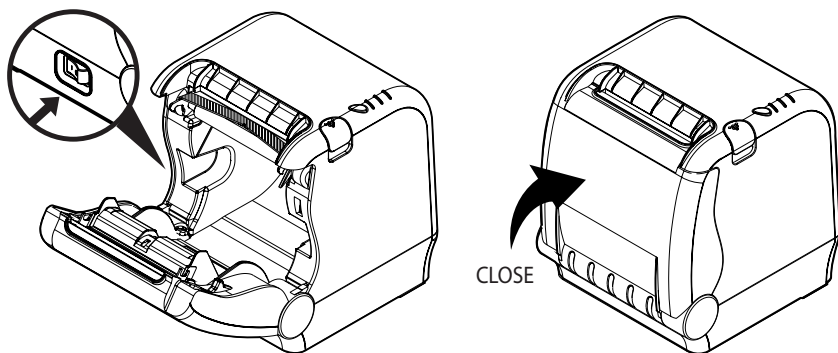

3. Control panel and other functions

3-1. Control panel

You can control the basic paper feeding operations of the printer with the button on the control panel. The indicator lights let you to monitor the printer's status.

Control Panel

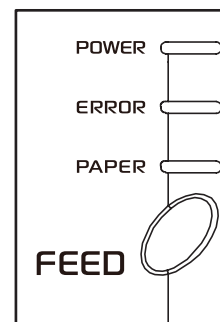

Button

The button can be disabled by the ESC c 5 command.

Press the FEED button once to advance paper one line. You can also hold down the FEED button to feed paper continuously.

3-2. Error indicators

This section explains the different patterns signaled by the two LED indicators located on the top cover of the printer.

STATUS	PAPER	ERROR	POWER	REMARKS
	RED	RED	GREEN	
Power off	OFF	OFF	OFF	Normal power is not supplied to the printer
Power on	OFF	OFF	ON	Normal power is supplied to the printer
On line	OFF	OFF	ON	Normal error-free mode
Cover open	OFF	ON	ON	Close cover
Paper empty	ON	ON	ON	Insert new paper roll
Test mode	OFF	OFF	ON	Ignored error led

4. Self Test

The self-test result indicated whether the printer is operating properly. Also with this, user can check following options or status of the printer.

- Control circuit
- Printer mechanism
- Printing quality
- ROM version
- Interface setting

This test is independent of any other equipment or software.

Running the self test

1. Make sure the printer is turned off and the printer cover is closed properly before performing the self test
2. Turn the printer on holding the FEED button, then the self-test will start. The self-test prints the printer setting value and then prints the following, and pauses. (Error LED On)

SELECT MODE BY BUTTON

1. ASCII PRINT
2. SELECT BAUDRATE MODE
3. HEXADUMP MODE
4. SELECT ERROR BEEP MODE

3. Press the FEED button consecutively (1~4)

1. ASCII PRINT (press the FEED button once)	Printing test page constructed with ASCII code.
2. SELECT BAUDRATE MODE (press the FEED button twice)	Set the speed of Serial Interface (You can set the BAUDRATE in this mode)
3. HEXADUMP MODE (press the FEED button triple time)	Printing the HEX value received from the interface
4. SELECT ERROR BEEP MODE	Select Printer Error Beep On/Off

♣ Wait for 5~6 seconds if you want to exit. Printer performs a cutting when exiting this mode

4. The printer is ready to receive data after finishing setting.

5. ASCII Print

ASCII PRINT is printing a test page constructed ASCII code. You can able to check the printer works properly with this

The ASCII PRINT test automatically ends and cuts the paper after printing the following:

***** Completed *****

The printer is ready to receive data as soon as it completes the ASCII PRINT.

6. Select Baudrate Mode

After entering the BAUDRATE MODE, the list which can select the BPS will be printed. Similar like Self Test, you can press the FEED button to select a BAUDRATE.

Once the input performs properly, the printer shows a result and store.

The printer is ready to receive data as soon as it completes the SELECT BAUDRATEMODE.

SELECT BAUDRATE BY BUTTON

1. 9600bps
2. 19200bps
3. 38400bps
4. 115200bps

7. Hexadecimal Dump

This feature allows experienced users to see exactly what data is coming to the printer. This can be useful in finding software problems.

When you go into the hex dump function, the printer prints all commands and other data in hexadecimal format along with a guide section to help you find specific commands.

To use the hex dump feature, follow these steps

1. Please turn printer off.
2. Please turn printer on while press down "Feed" button.
3. Press the FEED button three times when the Self Test printed.
4. Now printer had entered into Hexa dump mode.
5. Run any software program that sends data to the printer. The printer prints "Hexadecimal printing mode..." and then all the codes it receives in a two-column format. The first column contains the hexadecimal codes and the second column gives the ASCII characters that correspond to the codes.

Hexadecimal Dump

1B 21 00 1B 26 02 40 40 .!.& . @ @

1B 25 01 1B 63 34 00 1B .%.c4 ..

41 42 43 44 45 46 47 48 ABCDEFGH

A period (.) is printed for each code that has no ASCII equivalent.

6. Turn off the printer.

7. Turn on the printer.

8. Select Error Beep Mode

This function is to select the ON/OFF status of the buzzer mode when a printer makes errors such as a lack of paper, cover open etc.

Under this mode, you see the set-up menu printed like the down below.

Press the button once or twice to set up the ON/OFF mode.

SELECT ERROR BEEP MODE BY BUTTON

1. BEEP MODE ON
2. BEEP MODE OFF

9. Peripherals Connection

This product can communicate with other devices via Bluetooth or Wi-Fi(802.11a/b/g/n) communication and cable.

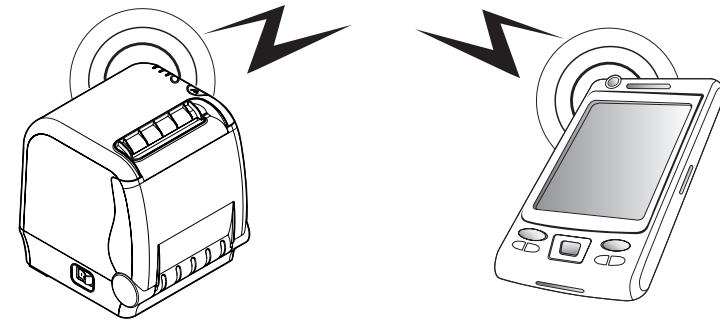

9-1. Bluetooth Connection Optional

1. The Printer can be connected to devices equipped with Bluetooth communication capacity (PDAs, PCs, etc.)
2. Use the Bluetooth connection function supported by the device to connect to the printer.

♣NOTE

Refer to the Bluetooth Manual for more details on connection.

9-2. Wi-Fi(802.11a/b/g/n) Connection Optional

1. The Printer can be connected to devices equipped with Wi-Fi(802.11a/b/g/n) communication capacity (PDAs, PCs, etc.)
2. Use the Wi-Fi(802.11a/b/g/n) connection function supported by the device to

♣NOTE

Refer to the Wi-Fi(802.11a/b/g/n) Manual for more details on connection.

10. Printer cleaning

If the interior of the printer is dusty, printing quality can be lowered. In this case, follow the instructions below to clean the printer.

♣Note :

1. Make sure to turn the printer power off prior to cleaning
2. Regarding print head cleaning, as the print head is very hot during printing, turn off the printer power and wait approximately 10 minute before start.
3. When cleaning the print head, take care not to touch the heated part of the print head. The print head subject to be damaged by static electricity.
4. Take care not to allow the print head to become scratched and /or damaged in any way.

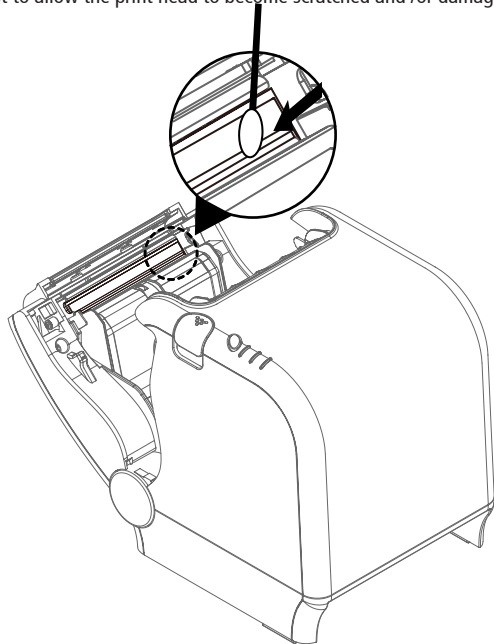

1. Use an applicator swab moistened with an alcohol solution to clean the print head and remove any dusts.
2. Once the cleaning is completed, insert paper roll into the printer few minutes later and close the printer cover.

♣Preventing Overheating

To prevent the motor from overheating, continuous operation of the printer should be 1.5 m or less in print length. Set the pause time for 30 seconds or more than it.

11. Specifications

♣Important!

When connecting or disconnecting the power supply from the printer, be sure that the following cautions are observed.

Use a power supply (Limited Power Supply) of DC 24V±10% and more than 1.75A.

Be careful about installing the printer in an area where there is electrical noise.

Take the appropriate measure to protect against electrostatic AC line noise, etc.

11-1. General Specifications

- | | |
|-----------------------------|-------------------------------|
| (1) Printing Method | Direct line thermal printing. |
| (2) Print speed | 220mm/sec |
| (3) Dot density (Hor / Ver) | 180 DPI X 180 DPI |
| (4) Dot Pitch | 0.141mm X 0.141mm |
| (5) Printing Width | Max 72mm (512 dots/Line) |

(6) Number of print columns.

Font "A"	Font "B"
42 columns	56 columns

- | | |
|----------------|--|
| (7) Roll paper | Refer to chapter 2 for details on the recommended roll Paper.
Paper width : Default 79.5 ±0.5mm
Roll diameter : Max. ø83mm |
|----------------|--|

- | | |
|------------|--------|
| (8) Weight | 1.7 Kg |
|------------|--------|

(8) Overall dimension

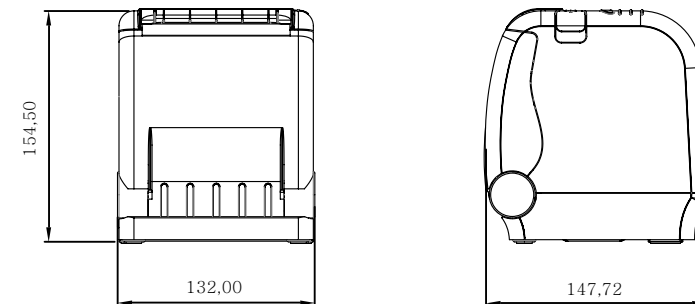

11-2. Auto Cutter Specifications

- (1) Cutting Frequency Max. 30 cuts per minute
- (2) Thickness of paper 0.06 ~ 0.08 mm
- (3) Cutter Life 1.5 million cuttings
(if the paper thickness is between 65 and 80µm)

11-3. Communications

USB (B type) + Serial Built-in / OPTION: Bluetooth 4.2 or Wi-Fi(a/b/g/n) 2.4/5GHz

11-4. Electrical Characteristics

- (1) Input Voltage DC 24V ± 10%
- (2) Current Consumption Operating: Approx. 1.5 A (at ASC II printing)
Peak : Approx. 10 A
(at print duty 100%, For 10 seconds or less)
Stand-by : Approx. 0.03 A
- (3) Power Connector

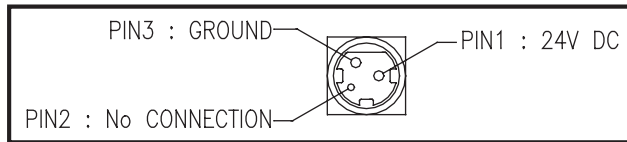

11-5. Environmental Requirements

- (1) Operating
Temperature 0°C to 45°C
Humidity 10% to 90% RH (without condensation)
- (2) Transport/Storage (except paper)
Temperature -20°C to 60°C
Humidity 10% to 90% RH (without condensation)

11-6. Reliability

- (1) MCBF 70 million lines
- (2) Head Life 100 million pulses, 150Km
- (3) Cutter Life 1.5 million cuttings (if the paper thickness is between 65 and 80µm)

11-7. Certification

- (1) FCC PART15 CLASS A
- (2) UL/cUL (UL 60950-1)
- (3) KC
- (4) CE-EMCD Class B
- (5) ENERGY STAR

This equipment is indoor use and all the communication wirings are limited to inside of the building.

12. Command List

No.	Command	Function	REMARKS
1	HT	Horizontal tab	
2	LF	Print and line feed	
3	CR	Print and carriage return	
4	FF	Print and return to standard mode(in page mode)	
5	CAN	Cancel print data in page mode	
6	DLE EOT	Real-time status transmission	
7	DLE ENQ	Real-time request to printer	
8	DLE DC4	Generate pulse at real-time	
9	ESC FF	Print data in page mode	
10	ESC SP	Set right-side character spacing	
11	ESC !	Select print mode(s)	
12	ESC \$	Set absolute print position	
13	ESC %	Select/cancel user-defined character set	
14	ESC &	Define user-defined characters	
15	ESC *	Set bit-image mode	
16	ESC -	Turn underline mode on/off	
17	ESC 2	Select default line spacing	
18	ESC 3	Set line spacing	
19	ESC =	Select peripheral device	
20	ESC ?	Cancel user-defined characters	
21	ESC @	Initialize printer	
22	ESC D	Set horizontal tab positions	
23	ESC E	Turn emphasized mode on/off	
24	ESC G	Turn double-strike mode on/off	
25	ESC J	Print and feed paper using minimum units	
26	ESC L	Select page mode	
27	ESC M	Select character font	
28	ESC R	Select an international character set	
29	ESC S	Select standard mode	
30	ESC T	Select print direction in page mode	
31	ESC V	Turn 90° clockwise rotation mode on/off	
32	ESC W	Set printing area in page mode	
33	ESC \	Set relative print position	
34	ESC a	Select justification	
35	ESC c 3	Select paper sensor(s) to output paper-end signals	
36	ESC c 4	Select paper sensor(s) to stop printing	
37	ESC c 5	Enable/disable panel buttons	
38	ESC d	Print and feed paper n lines	
39	ESC p	General pulse	

No.	Command	Function	REMARKS
40	ESC t	Select character code table	
41	ESC {	Turn upside-down printing mode on/off	
42	FS p	Print NV bit image	
43	FS q	Define NV bit image	
44	GS !	Select character size	
45	GS \$	Set absolute vertical print position in page mode	
46	GS *	Define downloaded bit image	
47	GS /	Print downloaded bit image	
48	GS B	Turn white/black reverse printing mode on/off	
49	GS H	Select printing position of HRI characters	
50	GS I	Transmit printer ID	
51	GS L	Set left margin	
52	GS P	Set horizontal and vertical motion units	
53	GS V	Select cut mode and cut paper	
54	GS W	Set printing area width	
55	GS \	Set relative vertical print position in page mode	
56	GS a	Enable/disable Automatic Status Back(ASB)	
57	GS f	Select font for HRI characters	
58	GS h	Set bar code height	
59	GS k	Print bar code	
60	GS r	Transmit status	
61	GS v 0	Print raster bit image	
62	GS w	Set bar code width	
	< Add >		
1	ESC i	Full cut	
2	ESC m	Partial cut	
3	FS !	Set print mode(s) for Kanji characters	
4	FS &	Select Kanji character mode	
5	FS -	Turn underline mode on/off for Kanji character	
6	FS .	Cancel Kanji character mode	
7	FS 2 c1 d1...dk	Define user-defined Kanji characters	
8	FS C	Select Kanji character code system	
9	FS S 1 2	Set Kanji character spacing	
10	FS W	Turn quadruple-size mode on/off for Kanji character	

